

Heavy Duty Single Monitor Screen Gas Spring Monitor Arm

Model: ACA-HMA-SGS01Y

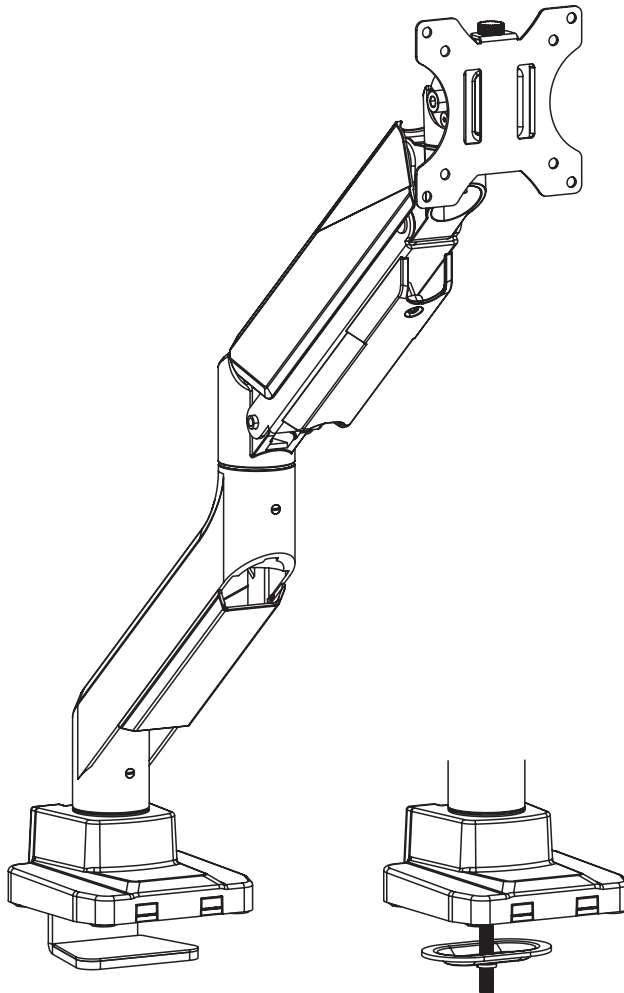

DO NOT RETURN TO STORE.

For warranty, missing parts or returns, please contact:

Please contact us at support@mbeat.com.au

Thank you for purchasing the

HEAVY DUTY SINGLE MONITOR SCREEN GAS SPRING MONITOR ARM

Thank you for purchasing this genuine, quality ACTIVIVA product.

Before you begin, to avoid choking hazard, please remove and safely discard or store any internal packaging material, promotional labels and protective covers fitted on the product.

When unpacking, check to see you have received all components and accessories, and retain the bulky packaging for warranty returns purposes.

This product is intended for indoor, household use only, and is not rated for outdoor, commercial or industrial use.

Please ensure the product is properly assembled or setup before use; follow the instructions provided in the manual.

We hope you enjoy your purchase as much as we did developing it.

If you have an issue with the product, warranty concerns, or any other queries, please feel free to get in touch with our friendly customer support team at support@mbeat.com.au

 **SUBSCRIBE TO MBEAT NEWS LETTER**
www.mbeat.com.au

 **LIKE AND FOLLOW US ON SOCIAL MEDIA**

 [mbeat_australia](https://www.instagram.com/mbeat_australia)

 [mbeat](https://www.facebook.com/mbeat)



 [mbeataustralia](https://twitter.com/mbeataustralia)

Read the entire instruction manual before you start installation and assembly.

CAUTION

Use with products heavier than the rated weights indicated may result in instability causing possible injury.

- Make sure that mounting surface is strong enough to handle a mounted product and equipment.
- DO NOT EXCEED THE MAXIMUM LISTED WEIGHT CAPACITY.
- Always use an assistant or a mechanical lifting device to safety lift and position heavy products.
- Tighten screws firmly, but do not over tighten. Over tightening can cause product damage that greatly reduces the holding power.
- Keep a clear area and distance from moving parts when using the product.
- This product may contain small items that could be a choking hazard if swallowed. Keep children away unless the product is intended for their use and all instructions and manuals are fully reviewed and understood by them.
- Check that the product is secure and safe to use at regular intervals (at least every three months).

 Flat panel monitor weight capacity: Max. 18kg
 Curved monitor weight capacity: Max. 14kg

INSTALLATION

⚠ IMPORTANT ⚠

Ensure that you have received all parts according to the component checklist prior to installation. If any parts are missing or faulty, contact your place of purchase for a replacement.



Recommend operation with 2 people.

1. Clamp Installation

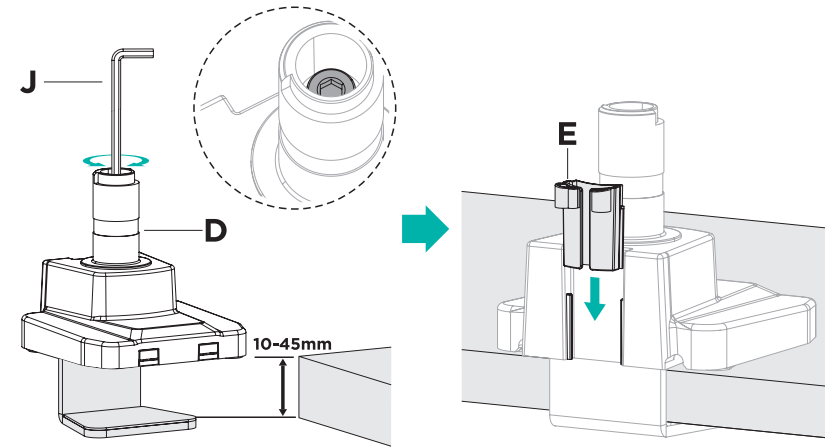

2. Grommet Installation

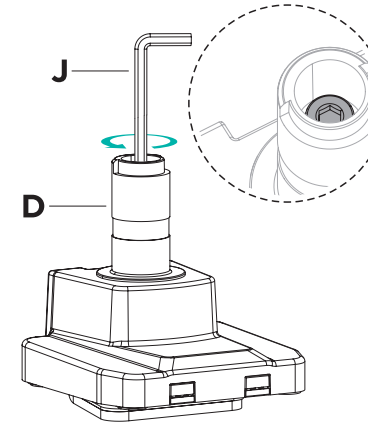

Desktop with Existing Through-Hole.

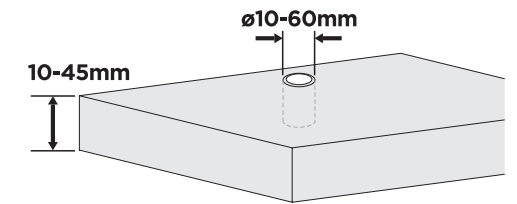

OR

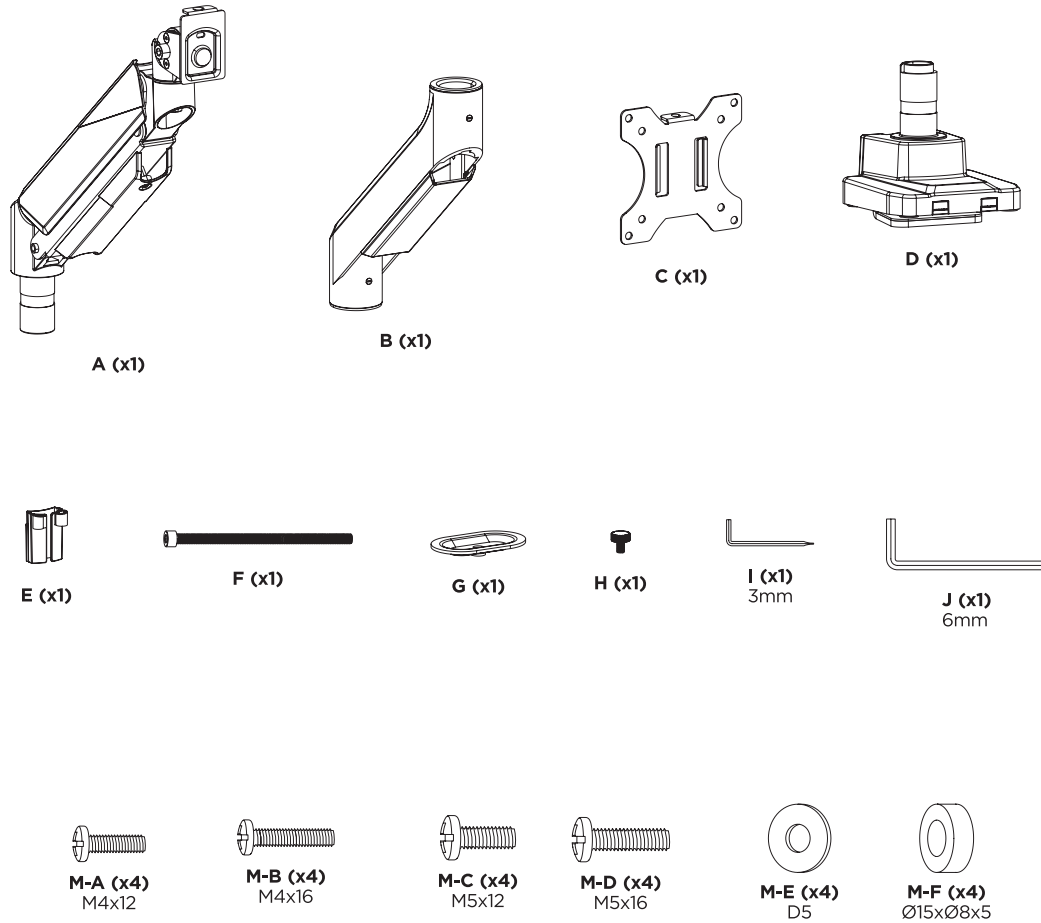
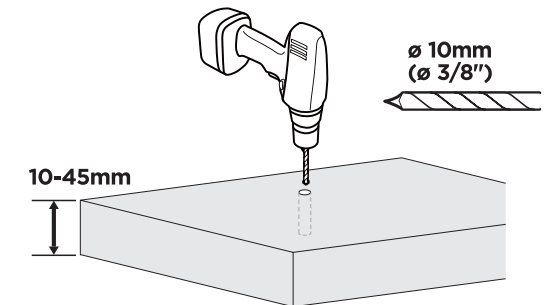

2. Grommet Installation

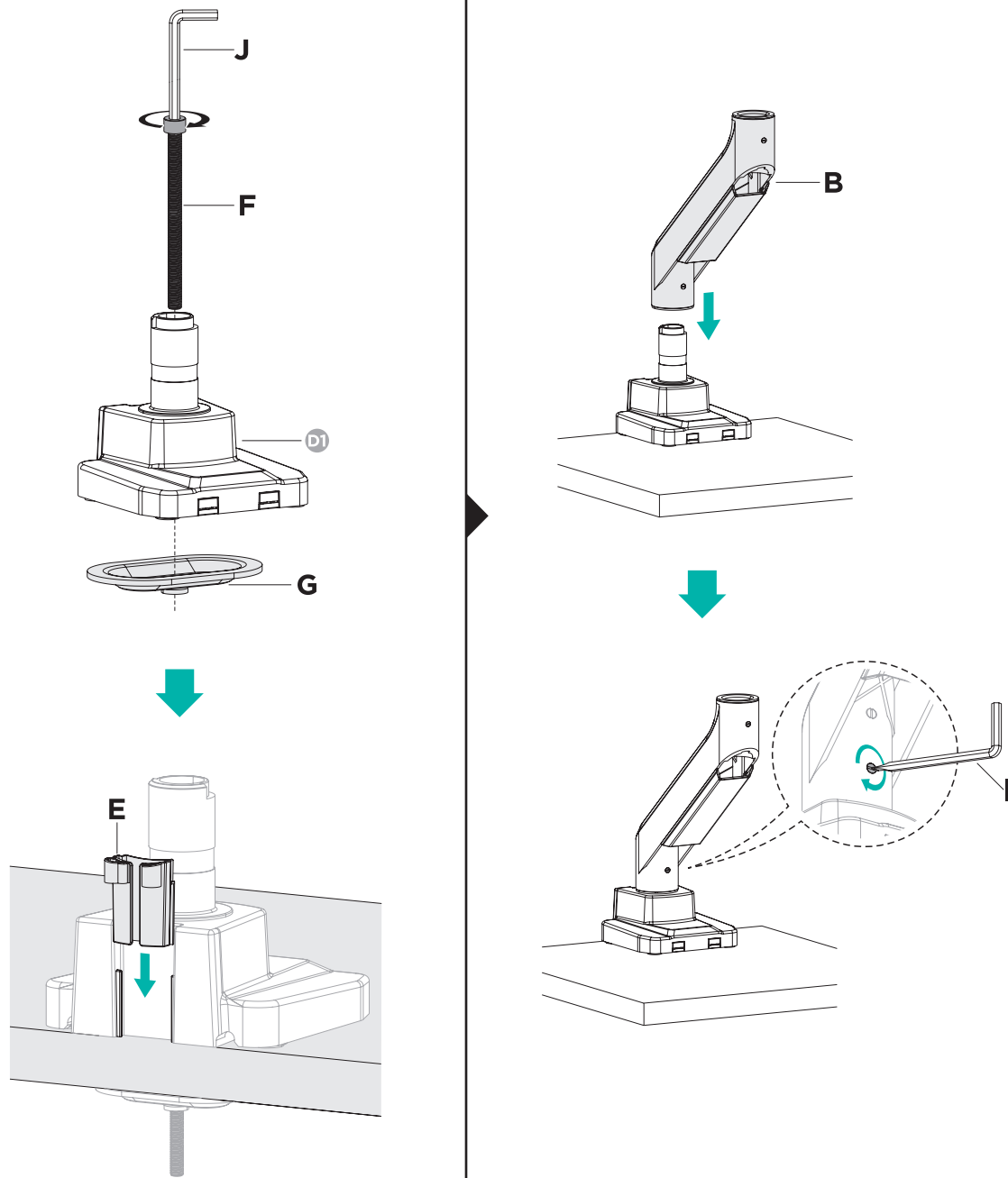

3.

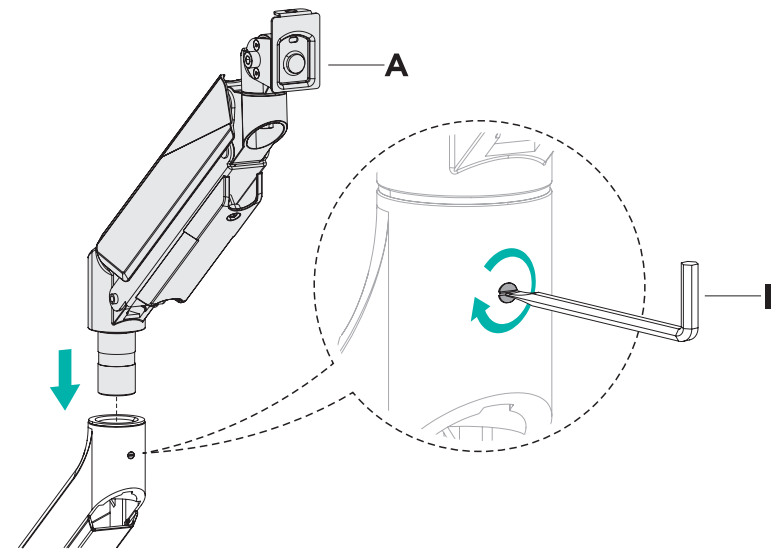

4.

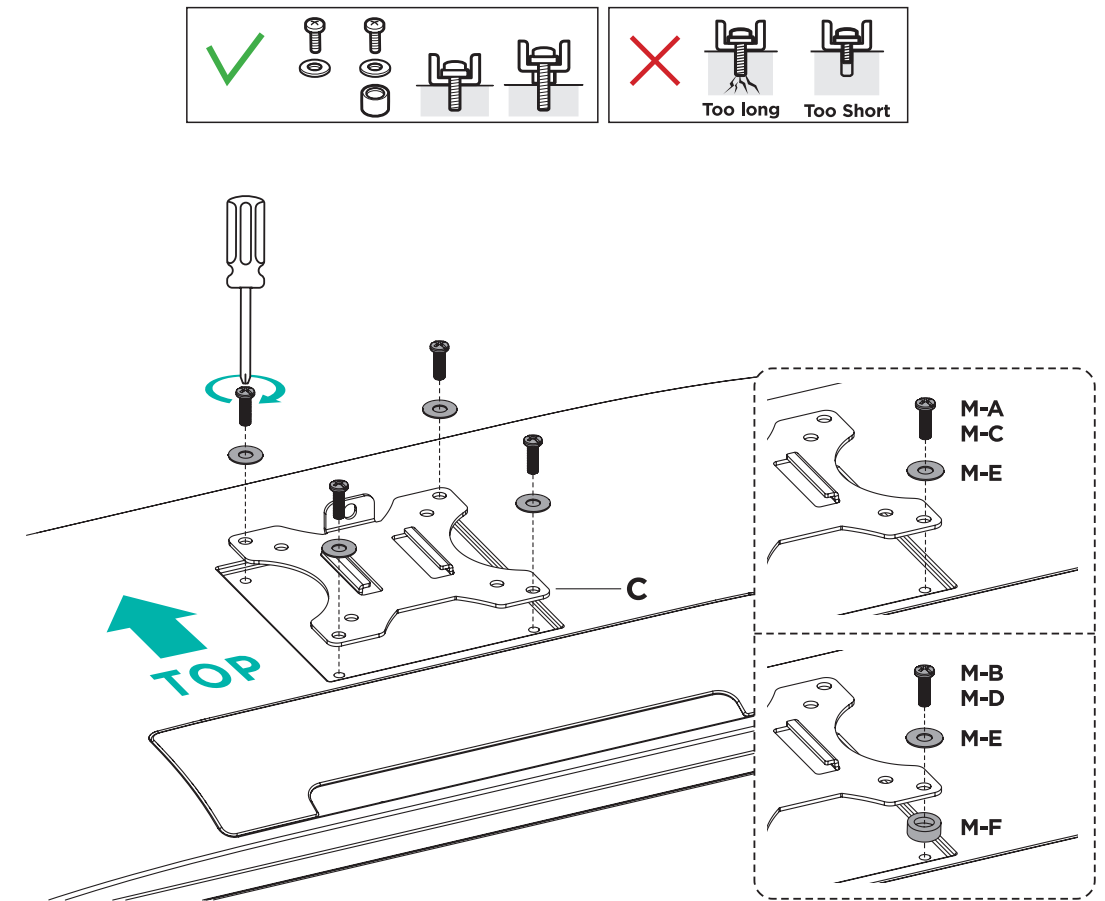

5.

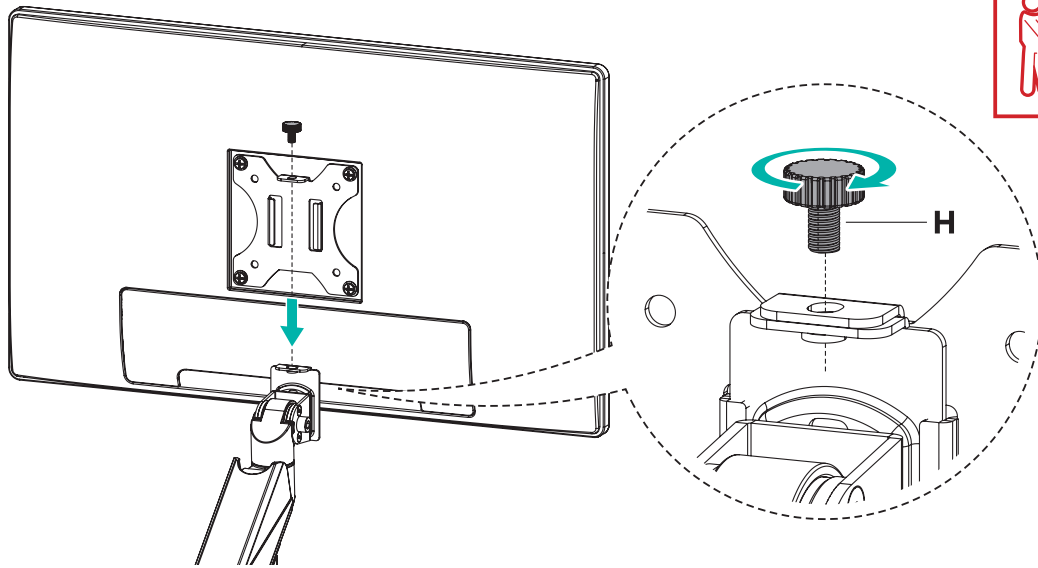

6.

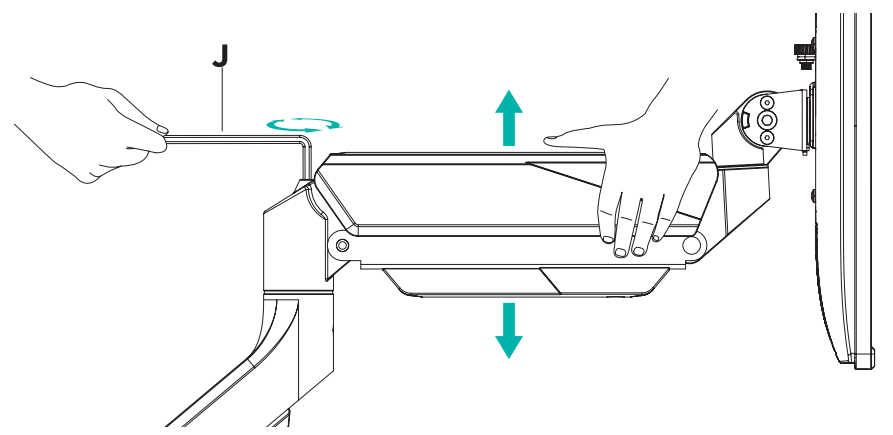

To properly balance the arm with monitors mounted, adjust the spring tension using the supplied Allen Key as follow:

First, position and firmly hold the arm horizontally as shown. Ask for assistance should you require it.

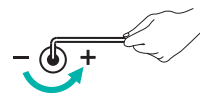

If the arm drops, turn the adjustment screw counter-clockwise until it stays in a horizontal position.

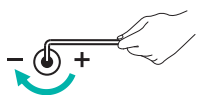

If the arm rises, turn the adjustment screw clockwise until it stays in a horizontal position.

⚠ DO NOT overtighten the screws.

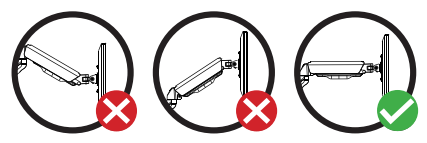

⚠ To avoid damage to monitors or mount, always keep the arm in a horizontal position while making adjustments. Ask for assistance if required.

7.

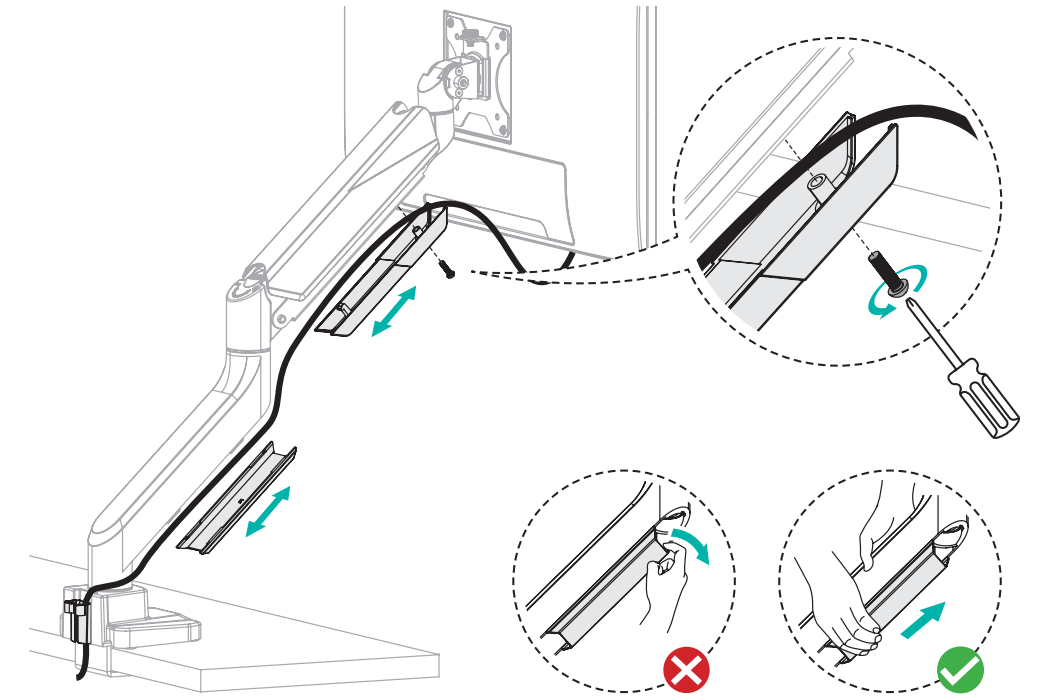

8.

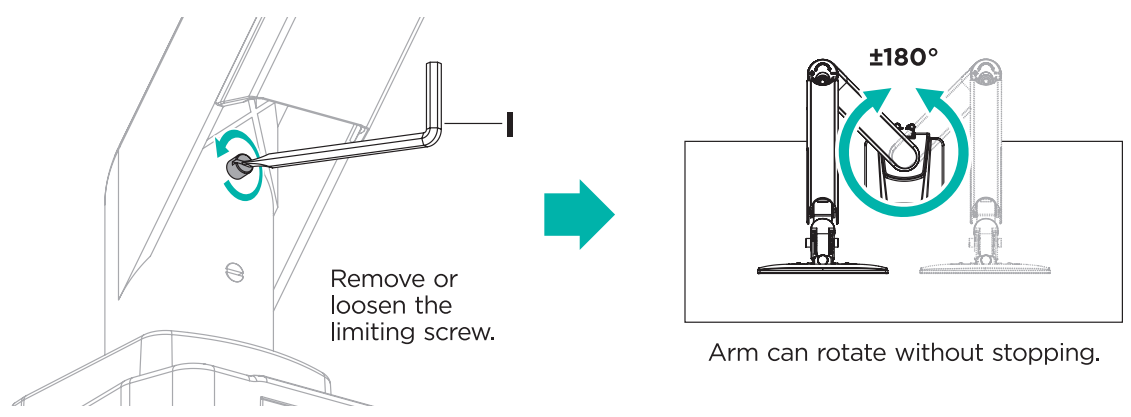
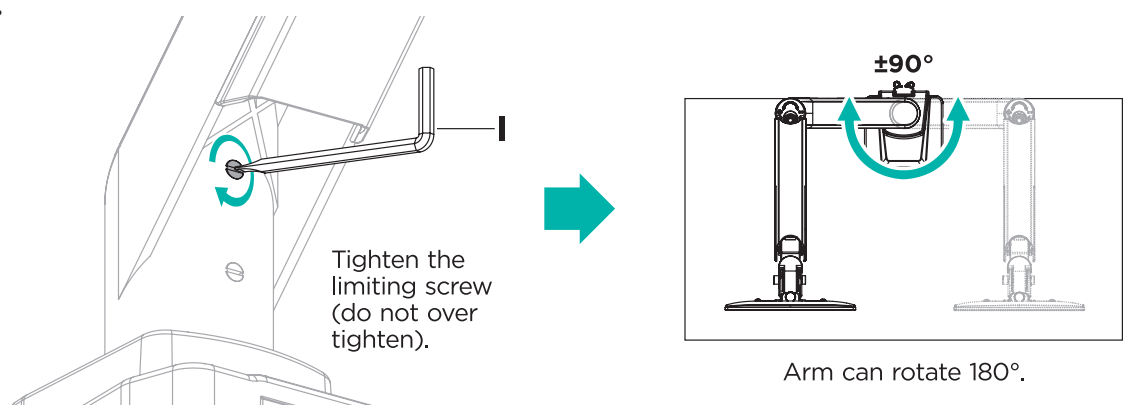

9.

Note: If the display does not stop at your desired position, tighten the screws as shown.

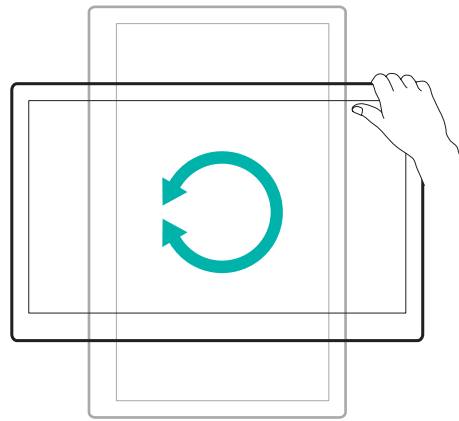
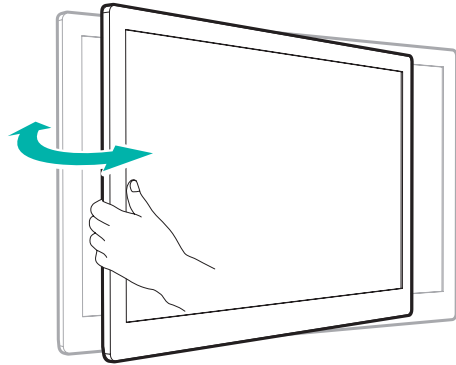
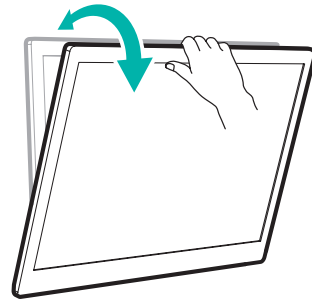
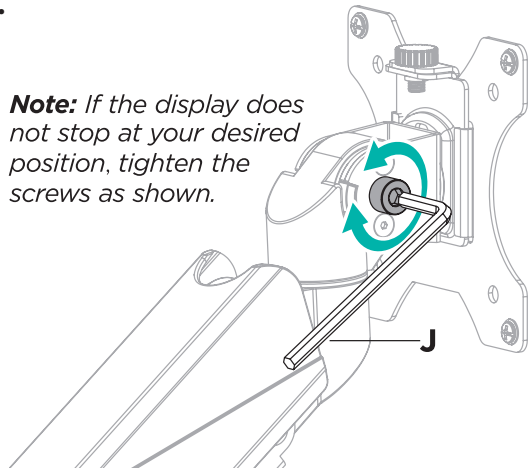

10.

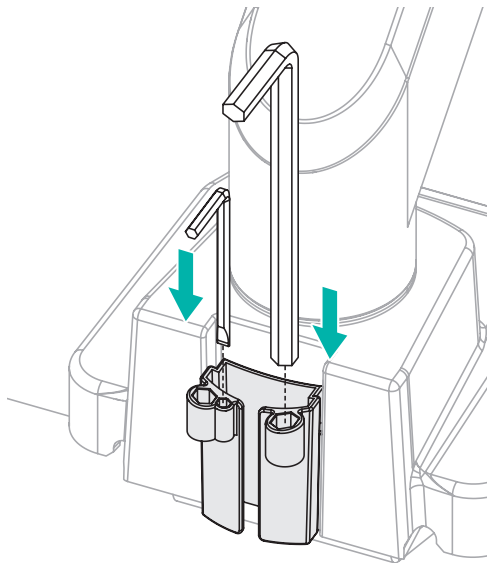

WARRANTY & CUSTOMER SERVICE INFORMATION

Please contact support@mbeat.com.au for all warranty support information and claims.

If you discover your product is defective within the specified warranty period, please contact Customer Support via support@mbeat.com.au with a copy of your invoice. **DO NOT** dispose of your product or packaging materials before contacting us. Make sure you obtain a **Return Merchandise Authority** number, or an **RMA** number from the Customer Support Team. Once our Customer Support Team has approved your request, they will provide details on how to return the product for repairs or replacement.

Please reference this **RMA** on the outer package for receiving. Items not labelled with **RMA** will be rejected on delivery. Please retain your tracking details in the event of a failed delivery.

Please ensure all returned products are; in its original packaging, in brand new condition, and with all manuals, cables and accessories included. Returned products that do not meet these conditions will not be eligible for an exchange. The packaging of returned products must not be missing or damaged in any way that may prevent its resale. Products should be returned in a shipping carton or other packaging so as to protect the branded product box. **Do not** write on or attach any shipping labels, stickers or sticky tape to the branded product box.

Products deemed faulty will either be repaired, replaced or refunded depending upon the nature of the fault. A shipping and inspection fee may be payable if no fault is found with your product. We will include an estimate of this fee in our correspondence with you.

We endeavour to get to every claim as soon as possible, we thank you for your patience and understanding in advance.

activiva

Disclaimer: activiva, mbeat and the mbeat logo are trademarks of Ultra Imagination Technology Pty Ltd. Images are for illustrative purposes only. Product specifications are subject to change without notice. mbeat is not liable for damages caused by improper use of this product.