



MB- PT-38 Series

USER MANUAL



Thank you for purchasing the MB-PT-38 turntable, please keep this manual for future reference.

The MB-PT-38 turntable is a true Hi-Fi experience, boasting a solid aluminum-cast platter with a belt drive system to dampen unwanted resonance and noise. Enjoy your favorite 33/45 RPM vinyl – or stream with Bluetooth via a smart device – using the built-in powerful speakers or plug directly into your own sound system with the unit's built-in pre-amplifiers. Complete with adjustable counterweight, moving magnet cartridge, tone and pitch controls to immerse yourself in uncompromising, authentic sound.

DO NOT RETURN TO STORE.

If you have an issue with the product, warranty concerns, or any other queries, please feel free to get in touch with our friendly customer support team at support@mbeat.com.au
Please visit mbeat.com.au for more product details.

 **SUBSCRIBE TO MBEAT NEWS LETTER**
www.mbeat.com.au

 **LIKE AND FOLLOW US ON SOCIAL MEDIA**

 [mbeataudio](https://www.instagram.com/mbeataudio)

 [mbeat](https://www.facebook.com/mbeat)

 [mbeataustralia](https://www.twitter.com/mbeataustralia)

CONTENTS

3	Safety Information
4	Technical Specifications
5	Product Details
7	Installing The Turntable
7	Installing The Lid
8	Turntable Platter And Belt Setup
8	Rotating The Platter
9	Cartridge Tracking Force Adjustment
10	Connection to External Speaker With RCA Audio Cable
12	Main Power Connection
12	Playing A Record
13	Bluetooth Speaker Operation
13	AUX-IN Operation
14	Product Care
14	Turntable Maintenance
15	Replacing The Stylus
15	Replacing The Belt
17	Safely Transport Your Turntable
17	Troubleshooting

SAFETY INFORMATION

To reduce the risk of fire, electric shock, or other injury, follow all instructions and safety guidelines.

1. This product is for indoor use only. Do not use this product near water.
2. This product should be operated only by the type of power source indicated on the marking label or in this instruction manual.
3. Protect the power cord from being stepped on or pinched, particularly at the joints.
4. Do not overload wall outlets, extension cords, or integral convenience receptacles as this can result in a risk of fire or electric shock.
5. Never push objects of any kind into this product through openings as they may touch dangerous voltage points or short-out parts that could result in a fire or electric shock.
6. Never spill liquid of any kind onto the product.
7. Do not attempt to service this product yourself as opening or removing covers may expose you to dangerous voltage or other hazards. Refer all servicing to qualified personnel.
8. Changes or modifications to this unit not expressly approved by the party responsible for compliance could void the user's authority to operate the equipment.
9. Do not use attachments not recommended by the product manufacturer as they may cause hazards.
10. Unplug the product in the event of a lightning storm or when unused for long periods of time.

FCC Statements

This equipment has been tested and found to comply with the limits for a Class B digital device, pursuant to Part 15 of the FCC Rules. These limits are designed to provide reasonable protection against harmful interference in a residential installation.

This equipment generates, uses, and can radiate radio frequency energy and, if not installed and used in accordance with the instructions, may cause harmful interference to radio communications.

However, there is no guarantee that interference will not occur in a particular installation. If this equipment does cause harmful interference to radio or television reception, which can be determined by turning the equipment off and on, the user is encouraged to try to correct the interference by one or more of the following measures:

1. Reorient or relocate the receiving antenna.
2. Increase the separation between the equipment and receiver.
3. Connect the equipment into a circuit different from that to which the receiver is connected.
4. Consult the dealer or an experienced radio TV technician for help.

TECHNICAL SPECIFICATIONS

Turntable

Power supply: DC 12V, 1500mA
Power consumption: Max. 35W
Turntable Speed: 33 1/3 & 45 RPM
Speaker Power (RMS): 18W×2 (Bluetooth Mode)
5W×2 (Phono Mode)
Product Dimensions: 44cm × 35cm × 19cm
Product Weight: 5.75kg
Stylus: AT3600

Stylus

Model: Audio-Technica AT3600
Frequency Response: 20Hz – 20kHz
Channel Balance: <2.5dB
Channel Separation: >18dB
Output Voltage: 2.5mV
Recommended Load Resistance: MM (Moving Magnet) – input
Recommended Tracking Force: 3.5±0.5g
Weight: 5.1g

NOTE: Design and specifications are subject to change without notice.

Package contents

1 × Turntable Unit	1 × Counterweight & Dial
1 × Lid Dust Cover	1 × DC Power Adapter
1 × Turntable Platter	1 × Instructional Manual & Accessories
1 × Drive Belt	
1 × 45 RPM Adaptor	1 × Pre-installed MMC Stylus

CAUTION

No user serviceable parts inside, warranty void if device opened.

This unit should not be adjusted or repaired by anyone other than qualified service professionals.

PRODUCT DETAILS

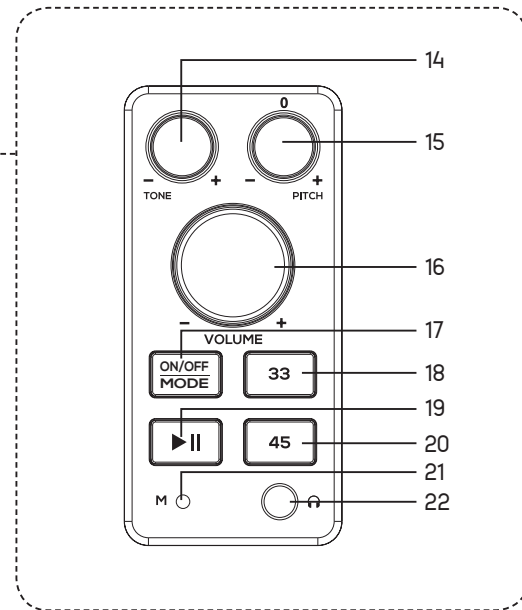
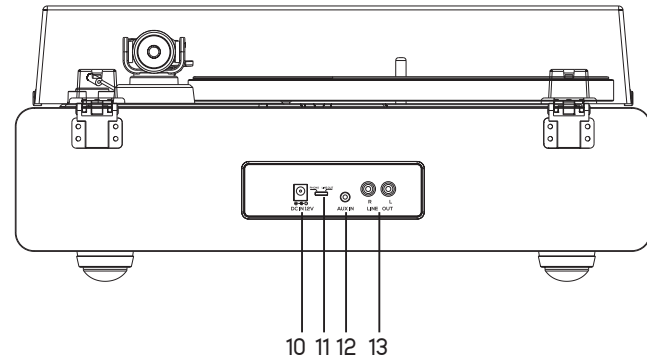
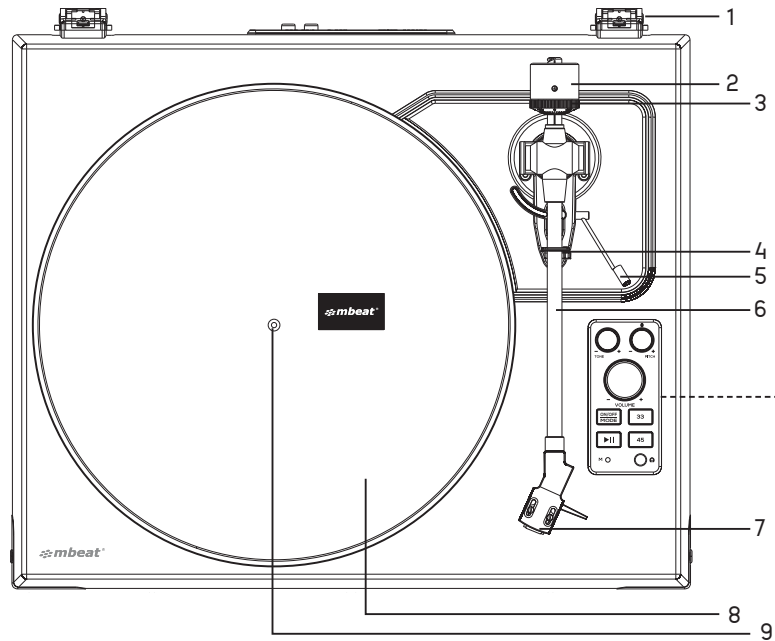

1. Lid Hinge

For dust cover attachment.

2. Counterweight

To balance the tonearm and adjust to provide the proper tracking force.

3. Tracking Force Dial

To adjust tracking force.

4. Tonearm Clip

To secure the tonearm.

5. Tonearm Lift

To move the tonearm to and from the record.

6. Tonearm**7. Stylus Cartridge****8. Turntable Platter**

Make sure the drive belt is looped in the middle of the platter.

9. Turntable Spindle**10. DC Input Jack**

Connect the DC power adapter.

11. Phono & Line Out Switch

Switch to Phono for connecting an amplifier with Phono input jack.

Switch to Line for connecting to the AUX jack of an amplifier.

12. AUX IN Jack

For details, refer to "Connection to External Speaker With RCA Audio Cable".

13. RCA Audio Out

For details, refer to "Connection to External Speaker With RCA Audio Cable".

14. Tone Control

To control record treble sound.

15. Pitch Control

To control record pitch sound.

16. Volume Control

To control volume up/down.

17. On/Off Mode Button (Power On/Off, Phono, BT mode)

Long press 3 seconds to turn on/off.

Short Press to switch between turntable player and Bluetooth.

18. 33¹/₃ RPM Speed Button

Select 33¹/₃ RPM speed for 33¹/₃ RPM record.

19. Play/Pause Button

Short press to play/pause the turntable player.

Short press to start the turntable player manually during power standby mode.

20. 45 RPM Speed Button

Select 45 RPM speed for 45 RPM record.

21. LED Indicator

Red states power on and turntable mode.

Blue states Bluetooth mode.

22. 3.5mm Headphone Jack

To connect to headphone.

INSTALLING THE TURNTABLE

Place the turntable on a level surface.

To avoid the effects of vibrations and acoustic pressure, DO NOT place the turntable next to items such as large external speakers.

The turntable may pick up static if placed next to a radio, avoid having radios nearby.

If the turntable is placed near electronic equipment that emits strong radio waves (such as a cell phone), noise can occur.

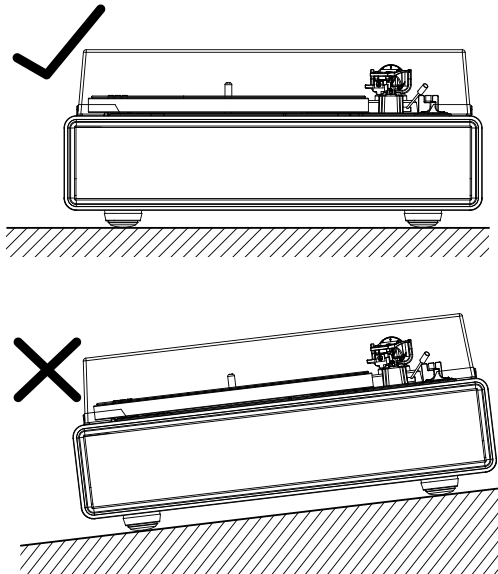

Scan the QR code for quick installation setup guide



WATCH VIDEO!

MB-PT-38 Hi-Fi Turntable with Speaker
Installation Video Guide

<https://www.youtube.com/watch?v=tUjzIY4S0cc&t=1s>

INSTALLING THE LID

Remove the lid from the packaging.

Slowly and gently insert the hinge pockets of the lid onto the hinges of the turntable.

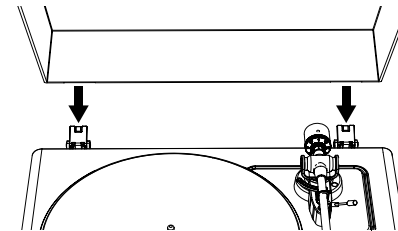

NOTE: It is recommended to install the lid at last to make it easier during setup and calibration.

TURNTABLE PLATTER AND BELT SETUP

1. Turn the platter over and check the belt position. Make sure that the drive belt is looped in the middle of the circle. If the belt is located too high or too low on the inner ring it may cause the drive belt to detach or speed to be unstable.

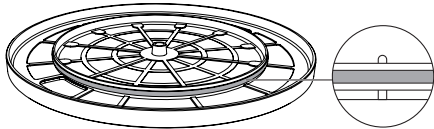

2. Set the platter on the spindle. Make sure the platter is fully seated on the spindle.

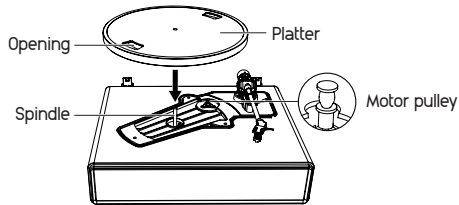

3. Place the belt on the motor pulley. Align one of the platter openings with the motor pulley, and while pulling both ends of the red ribbon that comes attached to the belt, place the belt on the motor pulley, as per the diagram. When doing this, be careful not to twist the belt.

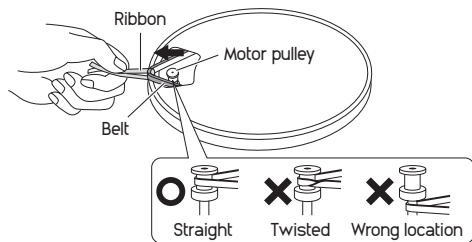

4. Finally, remove the red ribbon from the belt.

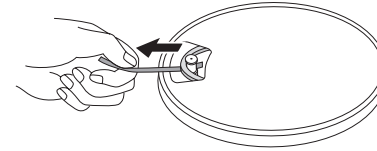

ROTATING THE PLATTER

1. Using your hands, slowly rotate the platter ten times in a clockwise direction.

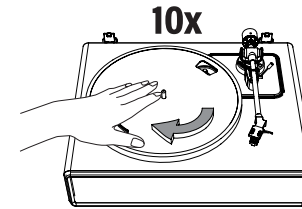

2. This step is for resetting the auto mechanism, getting rid of any twists in the belt and making sure the belt rides smoothly along the drive rim on the underside of the platter.
3. Place the slip mat on top of the platter. Make sure the logo on the mat is facing up.

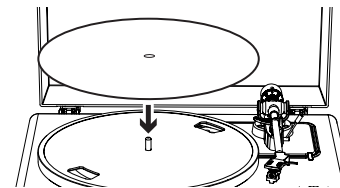

CARTRIDGE TRACKING FORCE ADJUSTMENT

The supplied Counterweight for this turntable is suitable for cartridge weighing between 3.0-6.0g.

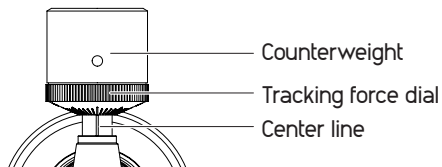

1. Gently push and turn the counterweight onto the rear of the tonearm (with the dial facing toward the front of the turntable).

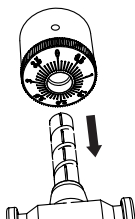

2. Pull the protector straight forward to remove it.

NOTE: Applying a downward force may cause the stylus to come off the body. Only low volume is output if the stylus has come off, or is about to come off, so refer to **"Replacing the stylus"** to reattach the stylus correctly.

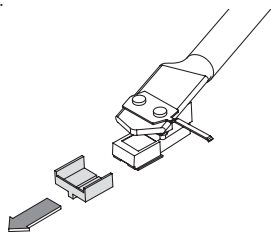

3. Remove the tie-wrap and unlock the tonearm.
4. Lower the tonearm lift lever and position the cartridge in the space between the tonearm rest and platter.

5. Carefully rotate the counterweight until the tonearm achieves a neutral balance. The tonearm should return to this balanced position if it is moved up or down. Take your time, this adjustment must be done carefully.

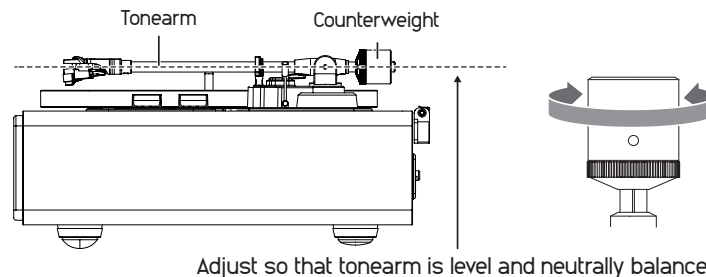

6. Once the tonearm is correctly balanced, return the tonearm to its rest and secure it in place with the clip. Hold the back of the counterweight to avoid moving its position, gently rotate the tracking force dial until the zero is in line with black center line on the rear of the tonearm. Check to make sure the tonearm is still neutrally balanced.

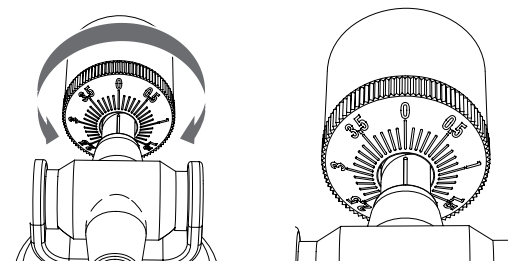

7. Finally, rotate the counterweight and tracking force dial together counterclockwise (as seen from the front) to adjust the tracking according to the cartridge manufacturer's recommendations.

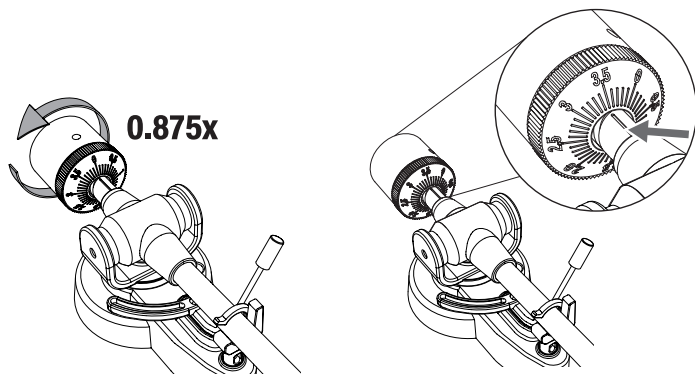

NOTE: Each mark on the scale represents 0.1g. The recommended tracking force for the factory-installed cartridge is 3.5g±0.5g. Carefully rotate the tracking force dial. When "3.5" is centered over the black line on the top of the tonearm please stop.

CONNECTION TO EXTERNAL SPEAKER WITH RCA AUDIO CABLE

This turntable includes 4 built-in speakers and a built-in phono equalizer.

If you wish to use your own amplifier or speakers, please follow the instructions below:

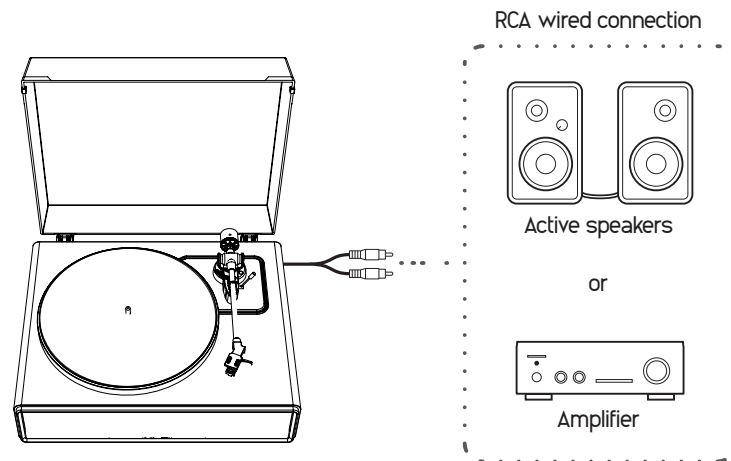

NOTE: In order to achieve the best sound, it is advised to set the turntable volume to a minimal level. The turntable's audio will be played back through your own amplifier, speakers, etc.

1. Setting pre-amplifier selector switch

This turntable has a built-in phono equalizer function. You can use the turntable even if you do not have a phono amplifier or compatible equipment with a built-in phono amplifier.

Use the pre-amplifier selector switch to set the output, as shown below.

Connectable equipment being used	Position of pre-amplifier selector switch	Where to connect RCA audio cable
Device with phono input	PHONO	Phono input jack and ground (earth) terminal of connectable equipment
Device without phono input	LINE	AUX or line input jack of connectable equipment

NOTE: The RCA Jacks are not designed to be connected directly to the passive/unpowered speakers on LINE mode. If connected to the passive speakers, there will be no sound.

2. Connecting the device

Align the settings for the pre-amplifier selector switch and connect the RCA audio cable to an input jack that is compatible with the connectable equipment you are using (amplifier, active speakers, etc.). The RCA audio cable's red jack is for the right (R) channel, and the white jack is for the left (L) channel.

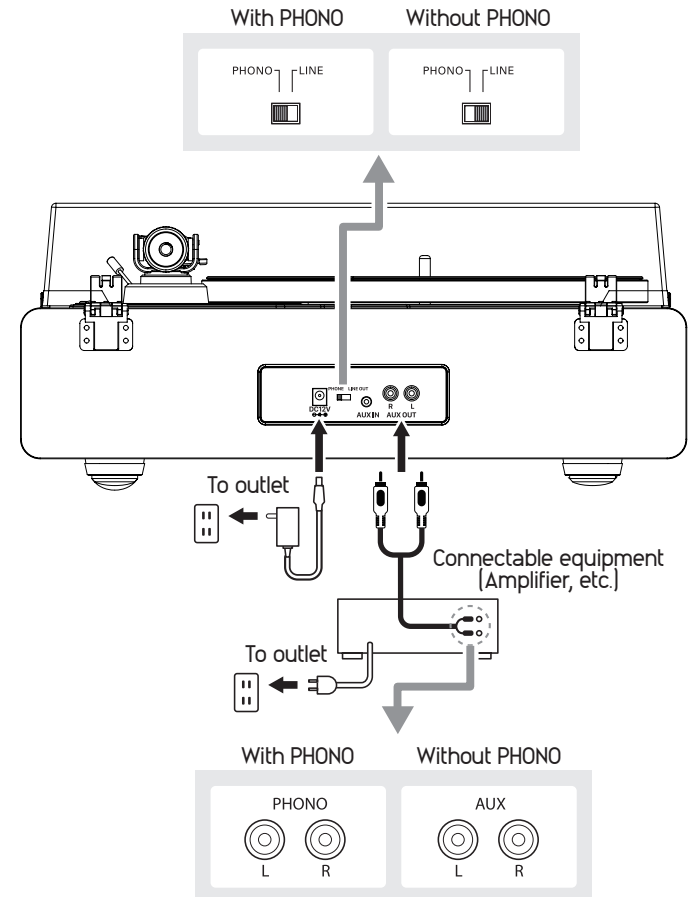

MAIN POWER CONNECTION

1. Insert the DC plug of the AC adapter cord into the DC INPUT Jack at the back of the turntable.
2. Plug the AC adapter into a normal power outlet.
3. Turn on the main power.

NOTE: Do not plug the AC power adapter into a power outlet before all turntable assembly is completed. Before turning on turntable power, recheck all connections to make sure they are correct and secure. Always turn off the turntable before connecting or disconnecting from power.

PLAYING A RECORD

1. Before playing a record

- 1.1. Pull the protector straight forward to remove it.

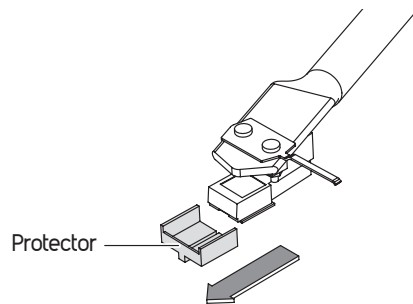

NOTE: Applying a downward force may cause the stylus to come off the body. Only low volume is output if the stylus has come off, or is about to come off, so refer to "Replacing the stylus" to reattach the stylus correctly.

- 1.2 Place the record on the felt mat so that the center hole aligns with the spindle.

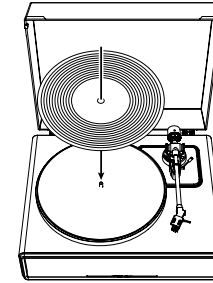

2. Turntable operation

- 2.1 Sufficiently lower the volume of the amplifier and speakers first.
- 2.2 Connect the included DC power adapter to the turntable, press and hold the **On/Off Mode** button for 3 seconds. The turntable will turn on. The indicator light will turn red.
- 2.3 Remove the stylus protector from the stylus.
- 2.4 Gently place the record on the slip mat.
- 2.5 Press the **33 $\frac{1}{3}$** or **45 RPM** speed button to switch between **33 $\frac{1}{3}$** and **45 RPM** speeds according to the type of record.
- 2.6 Press the **PLAY/PAUSE** button once and the platter will play or pause.
- 2.7 Unlock the tonearm clip and set the tonearm lift lever to the up position.
- 2.8 Position the tonearm over the desired location (groove) on the record.
- 2.9 Carefully lower the tonearm on the record.
- 2.10 Turn up the volume of the turntable as needed.
- 2.11 Finely tune the **Tone** and **Pitch** control buttons to customize your personal music experience.
- 2.12 When you are finished playing the record, raise the tonearm, return it to rest on the arm clip and press and hold the **On/Off Mode** button again to turn off the turntable completely.
- 2.13 Close the lid after using the turntable.

BLUETOOTH SPEAKER OPERATION

1. Connect the included power adapter to the turntable and long press the **On/Off Mode** button to turn on the power of the turntable, make sure that the indicator light turns red.
2. Press the **On/Off Mode** button shortly to switch in between the Phono or Bluetooth mode. When the Bluetooth mode turns on, the indicator light turns blue and flashes quickly. You will also hear an activation sound from the turntable.
3. Turn on the Bluetooth feature of your media device and search for and select "**MB-PT-38**" to pair the media device and turntable.
4. Once your media device is successfully paired with the turntable, the turntable will play a short confirmation sound.
5. Play and stream music from your media device to the turntable speakers. The indicator light will become solid.

AUX-IN OPERATION

This turntable includes the 3.5mm auxiliary audio signal input jack for connecting external audio devices like MP3 players, CD players, iPods or smartphones so you can listen to your external source through the turntable's speakers.

1. Use an audio cable (not included) with one 3.5mm stereo connection on each end of the cable.
2. Plug one end into the **AUX-IN Jack** on the turntable and the other end to the **Line Out Jack** of the audio device.
3. Press and hold the **On/Off Mode** button to power on the turntable and audio device. The indicator light of the turntable is red. When the AUX-IN is plugged in, the turntable set to default AUX-IN mode automatically.
4. The volume level can be controlled through the turntable. Operate all the functions on the auxiliary device as usual.
5. Please note that AUX-IN function is a first-priority function. Even if the indicator light for PHONO/BT is on, these functions won't work while the AUX-IN function is in use. Please unplug the AUX-IN cable before using the PHONO/BT functions.

NOTE:

- Please make sure that the tonearm is securely locked to avoid any damage.
- When you are done, don't forget to turn off the power on the turntable and your external device.

PRODUCT CARE

- Product designed for consumer and household application only.
 - *For your personal safety, no user serviceable parts inside. Warranty void if device opened.
- DO NOT operate under hot, humid or wet conditions.
- Prolonged exposure to loud sounds or music can lead to temporary or even permanent hearing loss.
- DO NOT operate or store turntable where it is subjected to direct sunlight, heat, excessive dust or vibration.
- DO NOT stop turntable or power-off mid-play; always raise the needle first.
- DO NOT leave vinyl record on the turntable after use; return the record to its original sleeve or storage.
- Return the tonearm to its original position after use and secure it with the tonearm clip.
- Replace the protective cap of the stylus after use.
- Close the turntable cover and to avoid dust build-up.
- Unplug the turntable during a lightning storm, or when not in use for long periods of time.

TURNTABLE MAINTENANCE

Turntable surface

- When the turntable surface is dirty or dusty, first disconnect the AC adapter and then wipe off the dirt and dust with a soft, dry cloth.
- Do not use benzenes, thinners, or other abrasive cleaning agents.
- When storing the product for a long time, disconnect the AC adapter from the outlet and wrap the product in plastic; do not allow it to become damp; the drive belt should be removed to prevent excessive stretching.

Stylus tip

- If dirt and grime are stuck to the stylus tip, clean it with a commercially sold brush.
- We recommend using a stylus tip brush when the tip is considerably dirty. Clean the stylus tip by moving the brush from the rear to the front of the stylus tip.

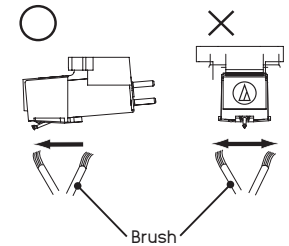

REPLACING THE STYLUS

It's recommended to replace the pre-installed AT3600 stylus after 400 hours of use.

Removing the stylus

- In addition to the deterioration of sound quality, records may also be damaged as the cartridge's stylus tip wears down.
- Be sure to disconnect the product's AC adapter from the outlet.
- When replacing the stylus, hold the head shell and the cartridge body tightly.

Rotate the front of the stylus in a forward and down motion.

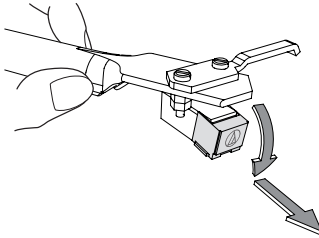

Installing a new replacement stylus

1. Mount the new replacement stylus to the cartridge.

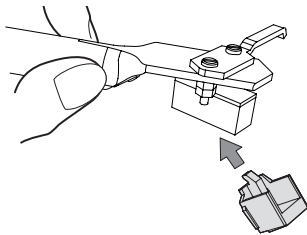

Engage in body first

2. Lift the stylus up until you hear a click.

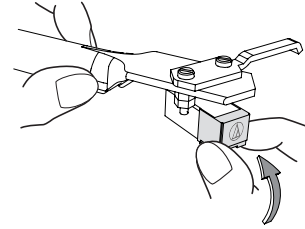

3. Make sure there is no gap between the head shell and the cartridge.

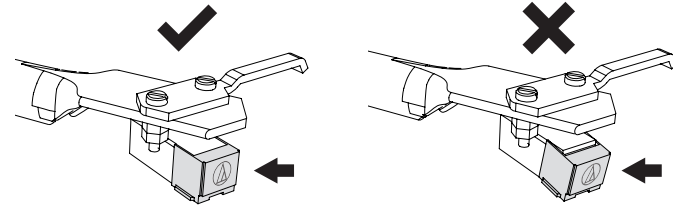

REPLACING THE BELT

The drive belt is a consumable part and can deteriorate over time. Replace the belt if the speed of playback slows down or irregular rotation occurs. As a rule of thumb, we suggest replacing the belt once a year. Before replacing the belt, be sure to disconnect the product's AC adapter from the outlet.

1. Remove the turntable mat.

NOTE: Remove the lid carefully for easy operation.

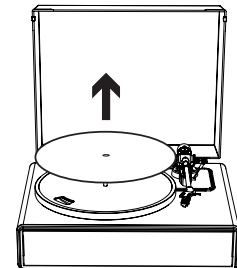

2. Remove the belt from the motor pulley.

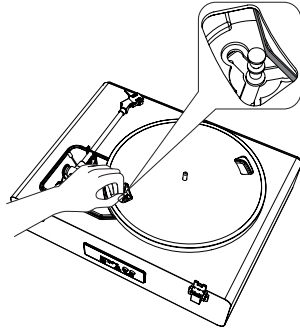

3. Remove the main platter and then remove the old belt.

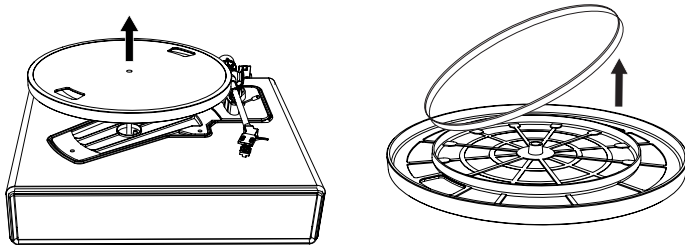

4. Turn the platter over and you will see a raised circle. Loop the new belt along the middle circle.

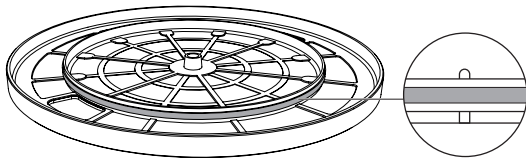

5. Attach the platter.

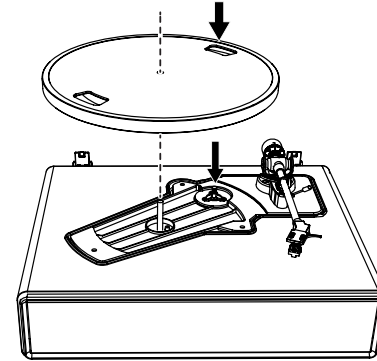

6. Place the belt on the brass-colored motor pulley. Grasp the belt that was attached in STEP 4 and, while pulling it, place it on the brass motor pulley.

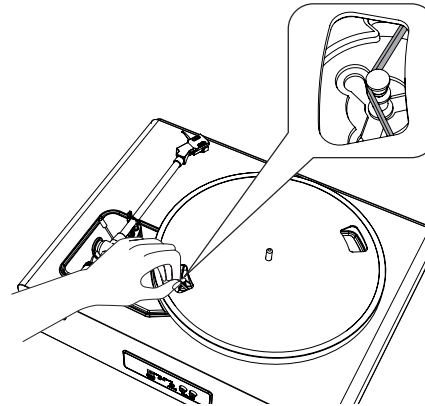

7. Using your hands, slowly rotate the platter ten times in a clockwise direction as shown by the arrow below.

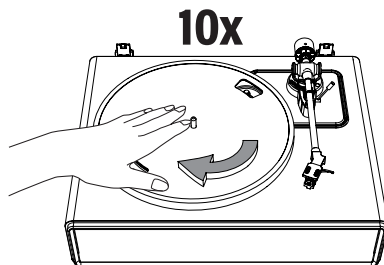

SAFELY TRANSPORT YOUR TURNTABLE

Using the product's original packing materials, wrap the turntable in the reverse order from when you unwrapped it. If you do not have the packaging materials, take the following measures:

- After disconnection the AC adapter from the outlet, remove the felt mat and platter, and then wrap them so that they do not get damaged.
- Attached the protector to the cartridge.
- Use a string or something similar to tie the tonearm to the rest so that it does not become dislodged.
- Wrap the turntable body with paper or a soft cloth so that it does not get damaged.

TURNTABLE TROUBLESHOOTING

1. THE PLATTER DOES NOT SPIN.

Is the AC adapter connected to the outlet?

- Connect the AC adapter to the outlet.

What's the status of the indicator light?

- The indicator light is blue. That means the turntable is in Bluetooth mode. Press the mode button to switch to Turntable mode.
- A red light will indicate Turntable mode is active.

Has the belt slipped from the platter?

- Correctly place the belt on the platter.

Is the belt placed on the motor pulley?

- Check that the belt is placed on the motor pulley (brass-colored) correctly.

Has the belt been damaged?

- Replace it with a new belt.

Is the AUX-IN cable plugged in?

- AUX-IN function is a first-priority function. Please unplug the AUX-IN cable before using the PHONO/BT functions.

2. THE PLATTER SPINS, BUT THERE IS NO SOUND FROM THE TURNTABLE.

Is the stylus damaged?

- Check the stylus and replace it if necessary. It's recommended to replace the stylus after 400 hours of use.

2. THE PLATTER SPINS, BUT THERE IS NO SOUND FROM THE TURNTABLE.

Is the stylus placed correctly on the body of the cartridge?

- Check the cartridge and adjust it, if necessary. If you run your fingers along the bottom of the stylus there should be scratching/static sounds coming from the speaker.

3. THE STYLUS SKIPS.

Is the record warped?

- Check the record.

Is the record scratched?

- Check the record.

Is the stylus downforce correct?

- Refer to “Cartridge Tracking Force Adjustment” to readjust the tracking force.

3. THE TURNTABLE IS MAKING A STRANGE ‘HOWLING’ SOUND.

Is the product picking up excessive vibrations from the floor, surface of the walls, or nearby speakers?

- Decrease the vibrations or mount the product on a surface that is not subject to the effects of vibrations.

Is the product mounted on an unstable surface?

- Check whether the surface on which the product is mounted is suitable.

4. THERE IS NOISE WHEN THE RECORD IS PLAYING.

Is there dust on the cartridge’s stylus tip?

- If dust is stuck to the stylus tip, clean it with a commercially sold brush.

5. THE SOUND WHEN THE RECORD IS PLAYING EITHER TOO FAST OR TOO SLOW.

Is the Tone/pitch incorrect for this record?

- Adjust the Tone/Pitch using the Tone/Pitch controls.

Is the belt installed correctly?

- Refer to “Turntable Platter and Belt Setup” to setup the belt.

Has the belt been damaged?

- Replace it with a new belt.

Are the speed settings for this record correct?

Please select the correct speed for the type of record being played.

6. PLAYBACK SPEED SLOWS DOWN OR THERE IS IRREGULAR ROTATION.

Is the belt stretched out?

- Replace with a new belt.

Is the belt installed correctly?

- Refer to “Turntable Platter and Belt Setup” to setup the belt.



Connect To Life.

Disclaimer: mbeat and the mbeat logo are trademarks of Ultra Imagination Technology Pty Ltd. All other trademarks, product names, logos, and brands are the properties of their respective owners. Product specifications are subject to change without notice. Images are for illustrative purposes only. Made in China. mbeat is not liable for damages caused by improper use of this product. © 2020 Ultra Imagination Technology Pty Ltd.