

# True HEPA Air Purifier

Model: MB-AP-01W, MB-AP-01K



---

## Questions or Concerns?

Please contact us at [support@mbeat.com.au](mailto:support@mbeat.com.au)

Thank you for purchasing the

# TRUE HEPA AIR PURIFIER

Thank you for purchasing this genuine, quality ACTIVIVA product.

Before you begin, to avoid choking hazard, please remove and safely discard or store any internal packaging material, promotional labels and protective covers fitted on the product.

When unpacking, check to see you have received all components and accessories, and retain the bulky packaging for warranty returns purposes.

This product is intended for indoor, household use only, and is not rated for outdoor, commercial or industrial use.

Please ensure the product is properly assembled or setup before use; follow the instructions provided in the manual.

We hope you enjoy your purchase as much as we did developing it.

---

If you have an issue with the product, warranty concerns, or any other queries, please feel free to get in touch with our friendly customer support team at [support@mbeat.com.au](mailto:support@mbeat.com.au)

---

 **SUBSCRIBE TO MBEAT NEWS LETTER**  
[www.mbeat.com.au](http://www.mbeat.com.au)

 **LIKE AND FOLLOW US ON SOCIAL MEDIA**

 [mbeat\\_australia](#)

 [mbeat](#)

 [mbeataustralia](#)

**PLEASE READ THE  
INSTRUCTIONS CAREFULLY  
BEFORE USE.  
STORE THIS MANUAL IN A  
SAFE PLACE FOR FUTURE  
REFERENCE.**

### Table of Contents

---

Specifications	3
Package Contents	3
Safety Information	4
Product Overview	7
Installing The Filter	8
Operation And Functions	8
Cleaning And Maintenance	10
Replacing The Filter	11
Troubleshooting	12
Warranty And Customer Services Information	14

Know More About Your

## TRUE HEPA AIR PURIFIER

**4-Step filtration system** – removes up to **99.95%** easy to setup and move around the house, with simple and intuitive controls to maximise air quality in an area up to **25m<sup>2</sup>**. Keeping it simple and clean.

**Difference you can smell** – 4-step air filtration system of preliminary particulates filter, medical grade H13 True HEPA air filter, activated carbon filter, UV-C germicidal light

**Quiet efficiency** – operating at **40dB** with Clean Air Delivery Rate (CADR) of **150m<sup>3</sup>/h** – enjoy clean air delivered quickly in an ambiance no louder than a quiet library.

### SPECIFICATIONS

<b>Input Power:</b>	DC 12V/2A
<b>CADR:</b>	150m <sup>3</sup> /h
<b>Noise Level:</b>	Speed High: Approx. 40dB Speed Mid: Approx. 35dB Sleep Mode: Approx. 25dB
<b>Filter:</b>	True HEPA H13 Filter Consisting of: Fine Preliminary Filter Layer + H13 HEPA Filter + Activated Carbon Layer
<b>Buttons &amp; Controls:</b>	Speed High, Speed Mid, Sleep, Filter, UV-C
<b>UV-C:</b>	UV-C tube light × 1
<b>Application Area:</b>	Up to 25m <sup>2</sup>
<b>Product Size:</b>	205mm × 205mm × 385mm
<b>Product Weight:</b>	2.1kg

### PACKAGE CONTENTS

<b>1 x</b> Air Purifier	<b>1 x</b> AC Adpater	<b>1 x</b> Manual
-------------------------	-----------------------	-------------------

## SAFETY INFORMATION

### General Product Safety

---

- **Do not** place the product near the edge of a bench or table during operation; ensure a clean, level surface free of moisture or water for optimal operation.
- **Do not** submerge product in water or other liquids.
- **Do not** use the product in the immediate surroundings of a bath, shower or swimming pool.
- **Do not** leave the product in operation unattended or without supervision.
- **Do not** use the product with an external timer, programmer or any other device that allows operation remotely without proper supervision.
- **Do not** run the power cord near a heat source such as radiators, stoves or heaters. Arrange the power cord away from traffic areas to avoid a tripping hazard.
- **Do not** unplug the product by pulling on the power cord.
- **Do not** operate the product with a damaged power cord or plug, or if the product has been dropped or damaged.
- **Do not** route power cord under rugs/ carpets, furniture or appliances.
- **Do not** insert foreign objects during operation or otherwise.
- **Do not** place anything directly on top of the product in operation or in storage.
- **Always** turn off and unplug the product before moving, cleaning & maintenance, or when not in use for extended periods of time.

## Electrical Safety

---

- Fully unwind the power cord before use.
- **Do not** let the power cord hang over the edge of a bench or table, touch hot surfaces or become knotted.
- **Do not** immerse the power cord, power plug or product in water or any other liquid or allow moisture to come in contact with parts of the appliance, unless otherwise recommended in the cleaning instructions.
- This product is not intended for use by persons (including children) with reduced physical, sensory or mental capabilities, or lack of experience and knowledge, unless they have been given supervision or instruction concerning use of the appliance by a guardian or carer of said individual.
- **Children** should be supervised to ensure that they do not play with the appliance. • It is recommended to regularly inspect the appliance. Do not use the appliance if power cord, power plug or product becomes damaged in any way.
- Any maintenance other than cleaning should not be attempted, for all services and repairs, please contact customer support.
- This product is for household use only. Do not use this appliance for anything other than its intended use. Do not use in moving vehicles or boats. Do not use outdoors. Misuse may cause injury.
- During electrical storms, the product should be disconnected from the power source at the wall socket to prevent damage to the product's electronic components.
- **Always** power off the product, switch off at the power outlet and unplug at the power outlet when the product is not in use.
- Before cleaning, always power off the product, switch off at the power outlet and remove the power cord, if detachable, from the product and allow all parts to cool.
- **Do not** place this product on or near a heat source, such as hot plate, oven, radiator or heater.
- Position the product at a minimum distance of **20cm away** from walls, curtains and other heat or steam sensitive materials and provide adequate circulation above and on all sides.

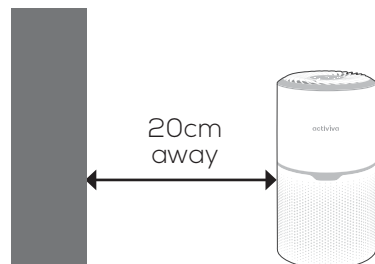

## Air Purifier Safety

---

- **Do not** attempt to repair or adjust any electrical or mechanical functions on this unit. Doing so will void your warranty. Other than the filter, the inside of the unit contains no user serviceable parts. For all servicing or repairs please contact customer support.
- **Do not** block the air openings, grills/ outlets or place on a soft surface such as a bed or sofa.
- This product contains a UV-C emitter. Unintended use of product or damage to the housing may result in the escape of UV-C light radiation. UV-C light radiation may cause harm to the eyes and skin.
- When moving the product, always lift the unit using two hands and set down gently on flat and level surface.
- Keep the product housing and dust filters clean. Follow the cleaning instructions provided in the manual.

# PRODUCT OVERVIEW

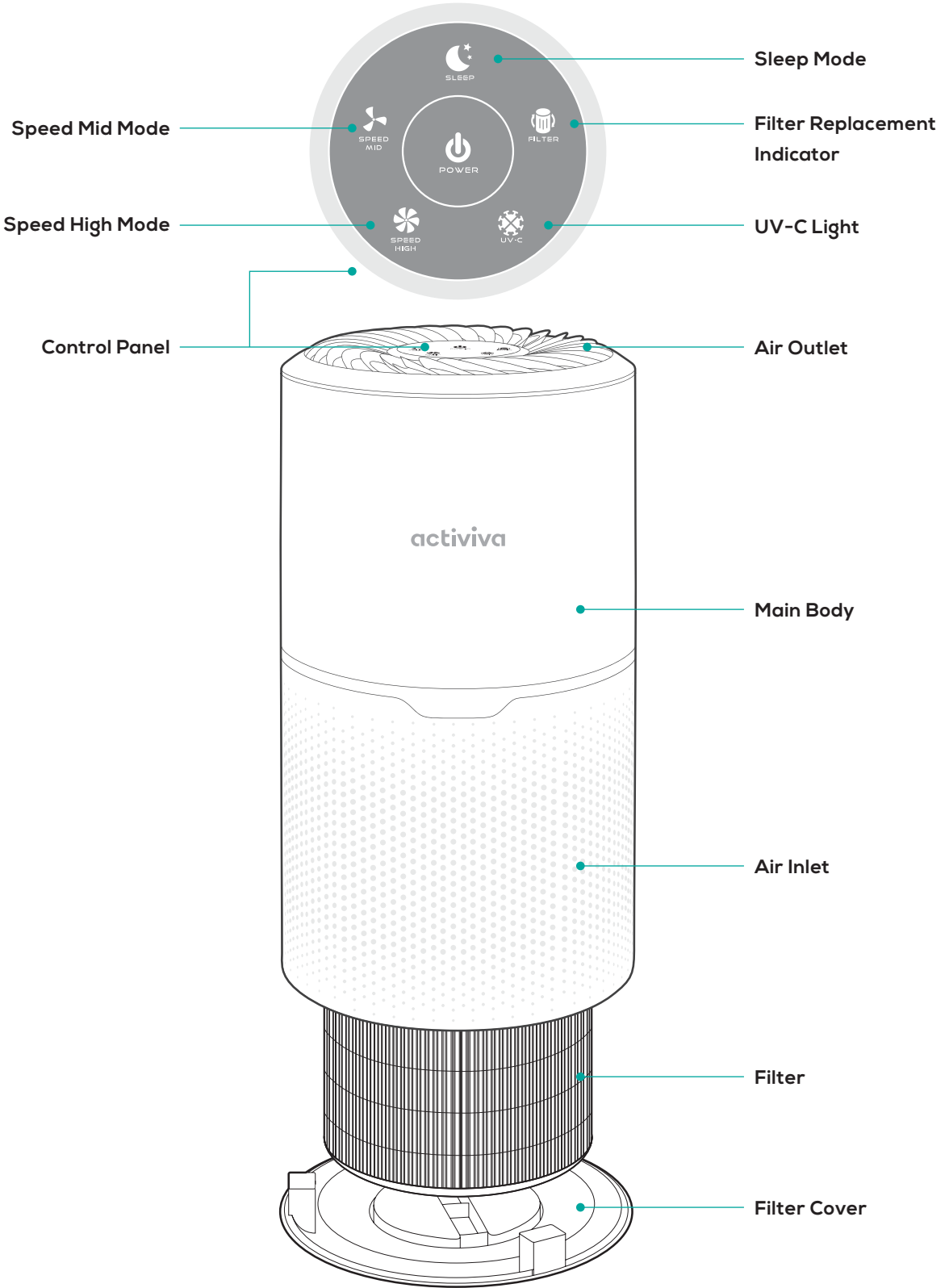



## INSTALLATING THE FILTER

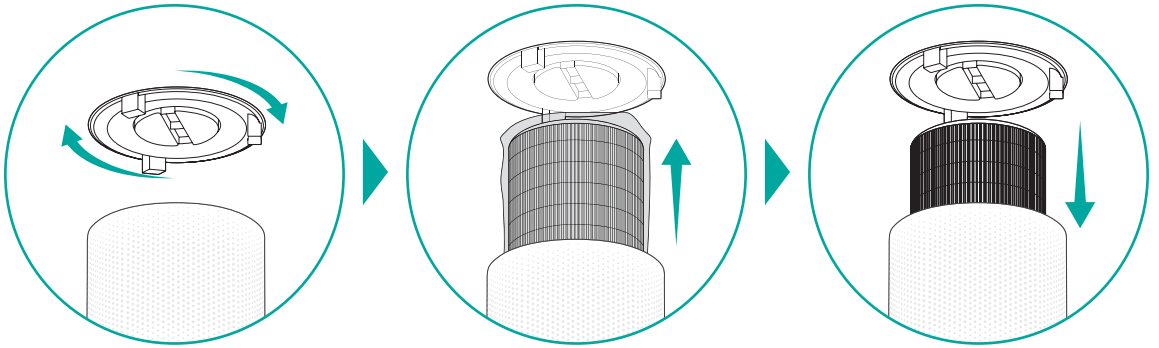

**1.** Turn the unit upside down and twist open the cover plate.

**2.** Take out the filter from the air purifier and remove it from its packaging, then replace it back in the purifier, making sure that it is centred.

**3.** Replace the cover plate, turning it clockwise to fasten it with click. Check that the cover is secure by pulling on it before operating.

## OPERATION AND FUNCTIONS

- To maximise airflow, place the unit at least **20cm** from any wall or furniture/curtains.
- Place the purifier on a flat and level surface.
- Make sure that the air inlet and outlets are not obstructed prior to switching on.
- Make sure the filter has been fitted correctly with the cover plate fully secured as described in Filter Installation.
- Plug the adaptor into a power outlet and connect it to the power inlet on the unit.
- Press the power button to begin; the purifier will automatically operate without any additional input.

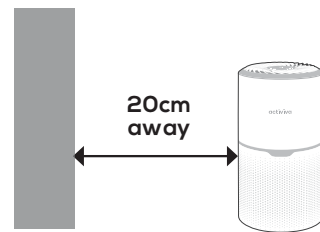





**Note:** While this purifier has been optimised to be low noise and energy efficient, some noise is to be expected, and you can hear it in operation in a quiet environment.

**Note:** When switching on after prior use, the purifier will automatically resume the last selected wind speed before powering off. Simply switch to another speed to change this.

## Functions

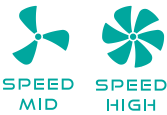
To activate any function, simply tap the corresponding icon on the interface. A light will indicate it is currently selected and in operation.

	<b>Power</b> Turns the air purifier on/off
	<b>Sleep</b> Sleep mode allows the purifier to operate quietly on the lowest speed setting while still cleaning the air.
	<b>Speed Mid and Speed High</b> Set the desired wind speed between medium and high – a higher speed is louder but cleans the air much faster.
	<b>Filter replacement warning</b> This indicator will light up when it's time to change the filter. See Replacing the Filter for further instructions. (See page 11)
	<b>UV-C light</b> The UV-C light can be switched off to keep the bedroom darker or save power.

**Note:** For best results, the air purifier should be positioned near the centre of the room and set to Speed High for 10 minutes to allow for air to circulate throughout the room. Once this is done, you can adjust the speed to suit your preference.

**Note:** It is recommended you clean your purifier and filter on a regular basis to increase its efficiency and extend the life of the filter. See **"Cleaning and Maintenance"** for further instructions. (See page 10)

**Warning:** Do not use a humidifier or aroma diffuser in conjunction with this product, as the filter can be compromised or damaged by the humidity or oils in the air.

## CLEANING AND MAINTAINENCE

**You should clean your purifier and filter once every month. You may need to clean it more frequently depending the environmental conditions.**

- Always make sure the air purifier is switched off and disconnected from the power outlet and allow all parts to cool before cleaning.
- **Do not** use any solvents or chemical agents in cleaning this device, as not to damage the product.
- **Do not** clean the filter with water or attempt to wash it, water or moisture will cause permanent damage and reduce the life of the filter.
- **Do not** use any hard bristle or brush, scrubs or any other abrasives that may damage the product.
- Use a clean, dry cloth to clean all external surfaces of the air purifier.

### Monthly Maintainence

---

#### Cleaning the air purifier:

- When cleaning, remove the filter and clean separately.
- Wipe down the body of the purifier with a clean, dry cloth. If required, use a damp cloth but dry the purifier immediately.
- Vacuum the inside of the air purifier with the filter removed, and wipe it down with a cloth if necessary.

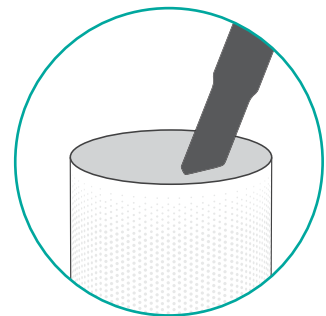

#### Cleaning the Filter:

- Make sure you're outside or in an environment where you don't mind getting a little dusty.
- Use a soft or non-abrasive brush to gently clean the inside and outside of the filter.
- Gently vacuum – on a lower setting as not to warp the filter – the inside and outside of the filter.

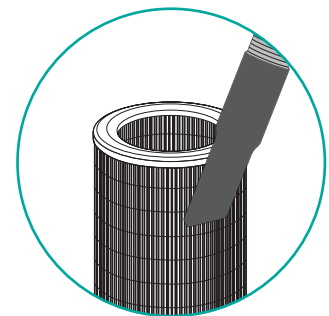

**Note:** Make sure you wear appropriate protective eye wear and face mask/ventilator to prevent inhaling, ingesting, or getting particulates into your eyes, nose or ears.

## REPLACING THE FILTER

Assuming constant use, the filter provided with the air purifier typically lasts between 6 to 8 months, and can last even longer with regular cleaning. Before requiring a replacement, a filter warning light will come on indicating that the filter has been in operation for a long time. You may not always need to replace the filter under these circumstances, but it is always a good idea to check and clean the filter when the light comes on.

- When removing old filter, be careful not to get any debris or dust into the fan mechanism of the purifier, as this would damage the unit. Keep the vacuum handy in case of such a scenario.
- Follow the steps from **“Installing the Filter”** (see page 8) and safely discard the old filter through appropriate means.
- Once installed, press and hold the warning light during operation to switch it off.

### You may need to replace the filter earlier if you notice any of the following:

- Louder noise during operation.
- Less airflow during operation.
- Unusual smell during operation.
- Visibly dirty or clogged up filter.

**Note:** Depending on the environment you use it in and how often you turn it on, the filter may need to be changed sooner or later than the warning light indicates. If you use the purifier in an area of high air pollution, you may find yourself needing to change the filter even if the filter warning light isn't switched on.

**This product uses a custom filter, product code: MB-FILT-AP01. To maintain the performance of your air purifier, please look for this filter from available retailers, or visit [www.mbeat.com.au](http://www.mbeat.com.au) to purchase online.**

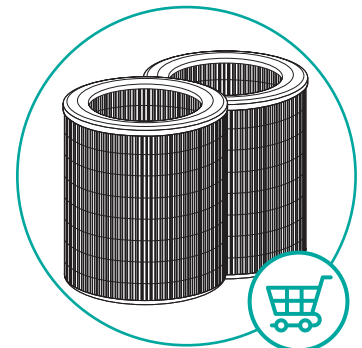
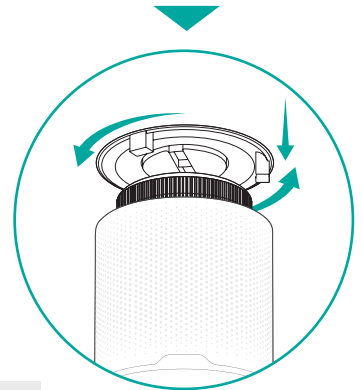
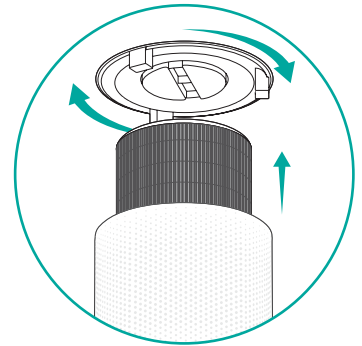

## TROUBLESHOOTING

### Air purifier will not turn on or respond to button controls

---

- Make sure the power is connected in the air purifier.
- Try to plug the air purifier into a different outlet.
- Check to see if the power cord is damaged.
- If the power cord or adapter is damaged, stop using the device and contact Customer Support (see page 14) **DO NOT** attempt to repair the purifier.

### Airflow is significantly reduced

---

- Make sure the filter is removed from its packaging and properly installed (see page 8).
- Make sure air inlet and outlet are not blocked or obstructed.
- Make sure there are at least 20cm of clearance on all sides of the air purifier.
- Increase the fan speed.
- The filter may be clogged by hair or lint, blocking airflow, clean the filter (see page 10)
- Filter may require replacing (see page 11).

### Air purifier makes an unusual noise while the fan is on

---

- Make sure the filter is removed from its packaging and properly installed (see page 8).
- Make sure the air purifier is operating on a hard, flat, even surface (not on the bed, or on an angle, or sideways).
- Make sure no objects are blocking the sides or top of the air purifier (the inlet or outlet)
- The filter may be clogged by hair or lint, blocking airflow, clean the filter (see page 10)
- Filter may require replacing (see page 11).
- Fan may be damaged, stop using the device and contact Customer Support (see page 14) **DO NOT** attempt to repair the purifier.

## **Strange smell coming from the purifier**

---

- Do not use the purifier in areas of high humidity or diffusing essential oils.
- Clean the filter or replace if necessary (see page 10-11).

## **Air purification quality is poor**

---

- Make sure no objects are blocking the sides or top of the air purifier (the inlet or outlet).
- Make sure the filter is removed from its packaging and properly installed (see page 8).
- Close doors and windows while using the air purifier.
- Make sure the room is smaller than 25m<sup>2</sup>.

**If your problem is not listed, please contact Customer Support (see page 14)**

## WARRANTY & CUSTOMER SERVICE INFORMATION

Please contact [support@mbeat.com.au](mailto:support@mbeat.com.au) for all warranty support information and claims.

If you discover your product is defective within the specified warranty period, please contact Customer Support via [support@mbeat.com.au](mailto:support@mbeat.com.au) with a copy of your invoice. **DO NOT** dispose of your product or packaging materials before contacting us. Make sure you obtain a **Return Merchandise Authority** number, or an **RMA** number from the Customer Support Team. Once our Customer Support Team has approved your request, they will provide details on how to return the product for repairs or replacement.

Please reference this **RMA** on the outer package for receiving. Items not labelled with **RMA** will be rejected on delivery. Please retain your tracking details in the event of a failed delivery.

**Please ensure all returned products are; in its original packaging, in brand new condition, and with all manuals, cables and accessories included.** Returned products that do not meet these conditions will not be eligible for an exchange. The packaging of returned products must not be missing or damaged in any way that may prevent its resale. Products should be returned in a shipping carton or other packaging so as to protect the branded product box. **Do not** write on or attach any shipping labels, stickers or sticky tape to the branded product box

Products deemed faulty will either be repaired, replaced or refunded depending upon the nature of the fault. A shipping and inspection fee may be payable if no fault is found with your product. We will include an estimate of this fee in our correspondence with you.

We endeavour to get to every claim as soon as possible, we thank you for your patience and understanding in advance.

# activiva

Disclaimer: activiva, mbeat and the mbeat logo are trademarks of Ultra Imagination Technology Pty Ltd. Images are for illustrative purposes only. Product specifications are subject to change without notice. mbeat is not liable for damages caused by improper use of this product.

---

Powered by 