

Universal Tablet and Smartphone Tripod

Model: ACA-TSTD-05BLK

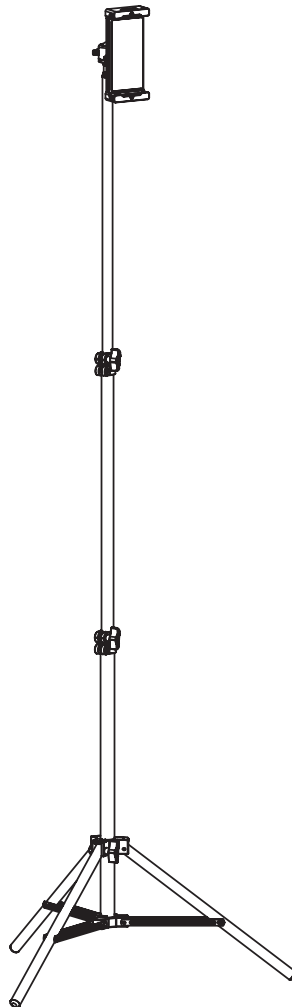

DO NOT RETURN TO STORE.

For warranty, missing parts or returns, please contact:

support@mbeat.com.au

Thank you for purchasing the

UNIVERSAL TABLET AND SMARTPHONE TRIPOD

Thank you for purchasing this genuine, quality ACTIVIVA product.

Before you begin, to avoid choking hazard, please remove and safely discard or store any internal packaging material, promotional labels and protective covers fitted on the product.

When unpacking, check to see you have received all components and accessories, and retain the bulky packaging for warranty returns purposes.

This product is intended for indoor, household use only, and is not rated for outdoor, commercial or industrial use.

Please ensure the product is properly assembled or setup before use; follow the instructions provided in the manual.

We hope you enjoy your purchase as much as we did developing it.

If you have an issue with the product, warranty concerns, or any other queries, please feel free to get in touch with our friendly customer support team at support@mbeat.com.au

 **SUBSCRIBE TO MBEAT NEWS LETTER**
www.mbeat.com.au

 **LIKE AND FOLLOW US ON SOCIAL MEDIA**

 [mbeat_australia](https://www.instagram.com/mbeat_australia)

 [mbeat](https://www.facebook.com/mbeat)

 [mbeataustralia](https://twitter.com/mbeataustralia)

Read the entire instruction manual before you start installation and assembly.

CAUTION

Use with products heavier than the rated weights indicated may result in instability causing possible injury.

- Please closely follow the assembly instructions. Improper installation may result in damage or serious personal injury.
- Safety gear and proper tools must be used. This product should only be installed by professionals.
- Make sure that the supporting surface will safely support the combined weight of the equipment and all attached hardware and components.
- Use the mounting screws provided and DO NOT OVER TIGHTEN mounting screws.
- This product contains small items that could be a choking hazard if swallowed. Keep these items away from children.
- This product is intended for indoor use only. Using this product outdoors could lead to product failure and personal injury.

 **Maximum Tablet Weight Capacity: 1kg**

INSTALLATION

⚠ IMPORTANT ⚠

Ensure that you have received all parts according to the component checklist prior to installation. If any parts are missing or faulty, contact your place of purchase for a replacement.

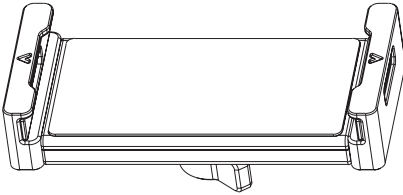

A × 1

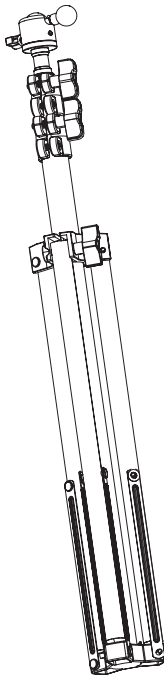

B × 1

Step 1

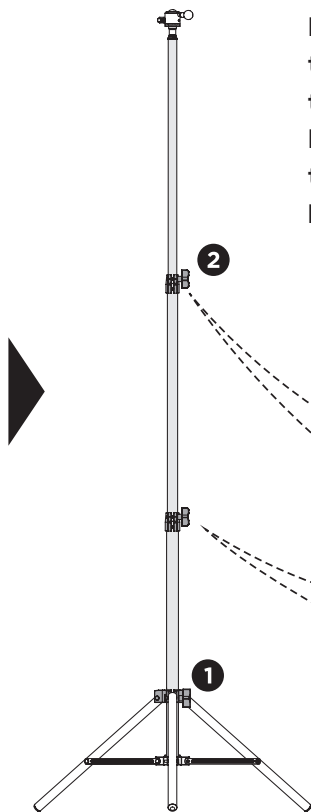
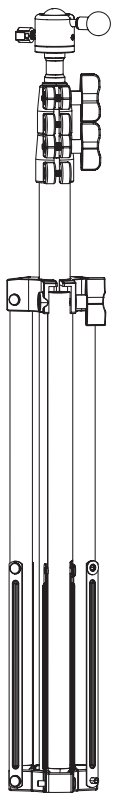

Release the locking knob to unfold the Tripod Stand (B) and then tighten the knob.
Loosen the height adjustable knob to adjust the pole to the desired height and then tighten the knob.

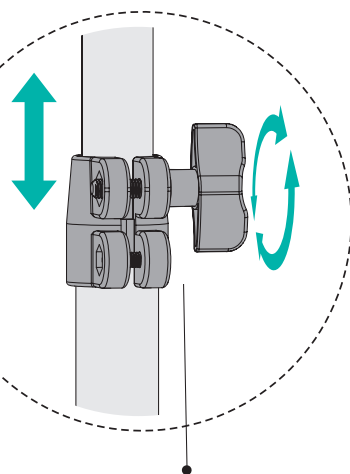

Height Adjustable Knob

1

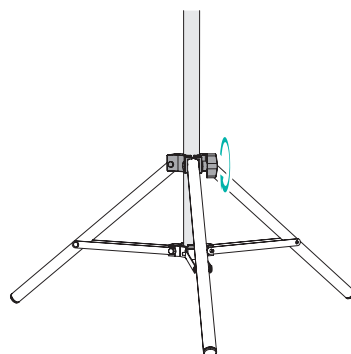
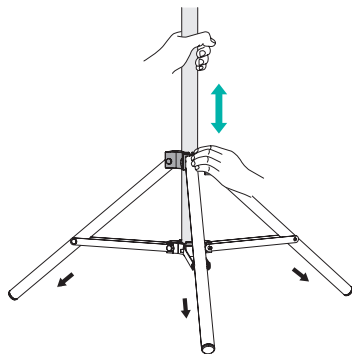

OPERATION

Step 2

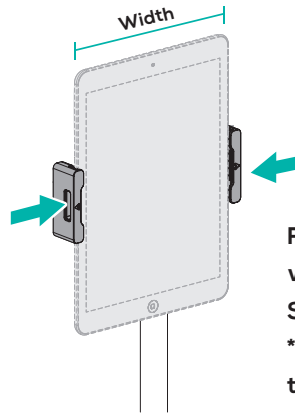
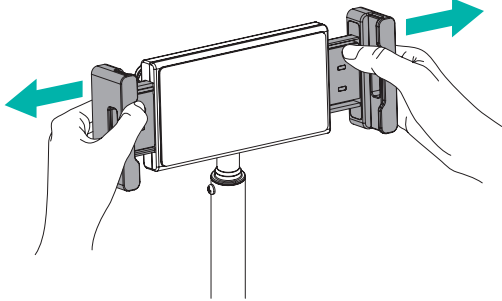
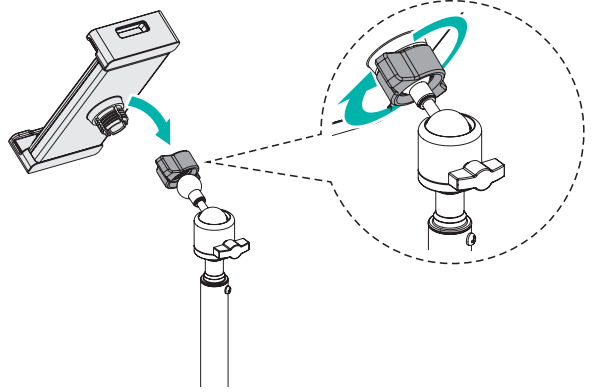
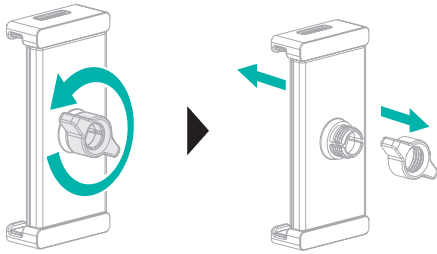

For iPad & Tablet with 4.7" to 12.9" Screens
*Note: Clamp the tablet width.

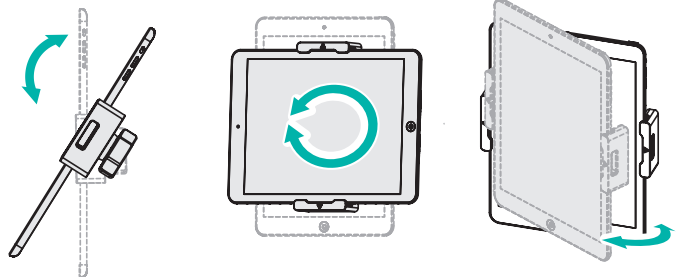
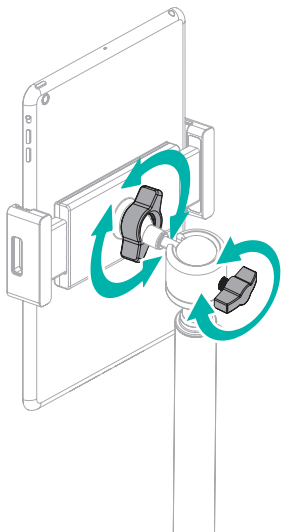

Note: Adjust the angle through loosening either one of the two knobs as shown.

WARRANTY & CUSTOMER SERVICE INFORMATION

Please contact support@mbeat.com.au for all warranty support information and claims.

If you discover your product is defective within the specified warranty period, please contact Customer Support via support@mbeat.com.au with a copy of your invoice. **DO NOT** dispose of your product or packaging materials before contacting us. Make sure you obtain a **Return Merchandise Authority** number, or an **RMA** number from the Customer Support Team. Once our Customer Support Team has approved your request, they will provide details on how to return the product for repairs or replacement.

Please reference this **RMA** on the outer package for receiving. Items not labelled with **RMA** will be rejected on delivery. Please retain your tracking details in the event of a failed delivery.

Please ensure all returned products are; in its original packaging, in brand new condition, and with all manuals, cables and accessories included. Returned products that do not meet these conditions will not be eligible for an exchange. The packaging of returned products must not be missing or damaged in any way that may prevent its resale. Products should be returned in a shipping carton or other packaging so as to protect the branded product box. **Do not** write on or attach any shipping labels, stickers or sticky tape to the branded product box.

Products deemed faulty will either be repaired, replaced or refunded depending upon the nature of the fault. A shipping and inspection fee may be payable if no fault is found with your product. We will include an estimate of this fee in our correspondence with you.

We endeavour to get to every claim as soon as possible, we thank you for your patience and understanding in advance.

activiva

Disclaimer: activiva, mbeat and the mbeat logo are trademarks of Ultra Imagination Technology Pty Ltd. Images are for illustrative purposes only. Product specifications are subject to change without notice. mbeat is not liable for damages caused by improper use of this product.

Powered by 